

Model

LS520A

12 Volt Input

Dual Tube CCFT Inverter

Brightness Control

Physical Specifications

Dimensions:	20mm x 130mm x 13.5mm (0.787" x 5.12" x 0.531")
Weight:	36g (1.28 oz.)
Operating Temp:	0 to 55°C, convection cooling
Relative Humidity:	20% to 90%, non-condensing
Storage:	-20 to 85°C/5-95% RH
Impact Resistance:	50G half wave per 2 msec
Vibration Resistance:	10-55-10 Hz/min @ 1.5mm



Input Specifications*

Item	Condition	Standard
Input Voltage Rated Tolerance	— Continuous Operation Starting Condition (Discharge Starting Voltage)	12 Vdc 9.6 Vdc - 14.4 Vdc 9.6 Vdc - 14.4 Vdc
Max. Input Current	$V_{IN} = 9.6$ Vdc Luminance @ Max.	1.2 A
Rush Current	$V_{IN} = 14.4$ Vdc Luminance @ Max.	5.0 A zero-p/20 μ S or less
Max. Input Power	$V_{IN} = 9.6$ Vdc Luminance @ Max.	11.6 W
On/Off Input Current	On/Off $L = 0.0 - 0.4$ Vdc $V_{IN} = 14.4$ Vdc	$I_{LOW} = -0.45$ mA or more (Lamp Lighting)
	On/Off H = Open or V_{IN}	— (Lamp Off)

*Above Specifications Occur @ 25 \pm 5°C

Output Specifications*

Item	Condition	Standard		
		MIN	TYP	MAX
Output Voltage (Vrms)	$V_{IN} = 9.6$ Vdc	1500	—	—
Tube Current (mA rms)	Luminance @ Max. ($V_{cont} = 0.0$ V) Luminance @ Min. ($V_{cont} = 2.5$ V)	6.3 2.5	7.0 3.0	7.7 3.5
Max. Power Output (W)	$V_{IN} = 12$ Vdc/Luminance @ Max.	—	—	3.9
Ignition Frequency (kHz)	Luminance @ Max.	50	60	70

*Above specifications occur @ 25 \pm 5°C & $V_{IN} = 9.6 - 15$ Vdc.

Model

LS520A

Insulating Withstand Voltage

Item	Rating Description	
Insulating Withstand Voltage	Primary - Secondary	2.0 kVA Impulse
Insulating Resistance	Primary - Secondary Winding - Core	500 Vdc More than 100 MΩ

* Apply voltage to pin 6.

Luminance Variance

Item	Condition	Applied Voltage	Output Current
Luminance @ Max.	Btwn. pin 6 & 7	Vcont = 0.0 V	7.5 mA
Luminance @ Min.	Btwn. pin 6 & 7	Vcont = 2.5 V	3.5 mA

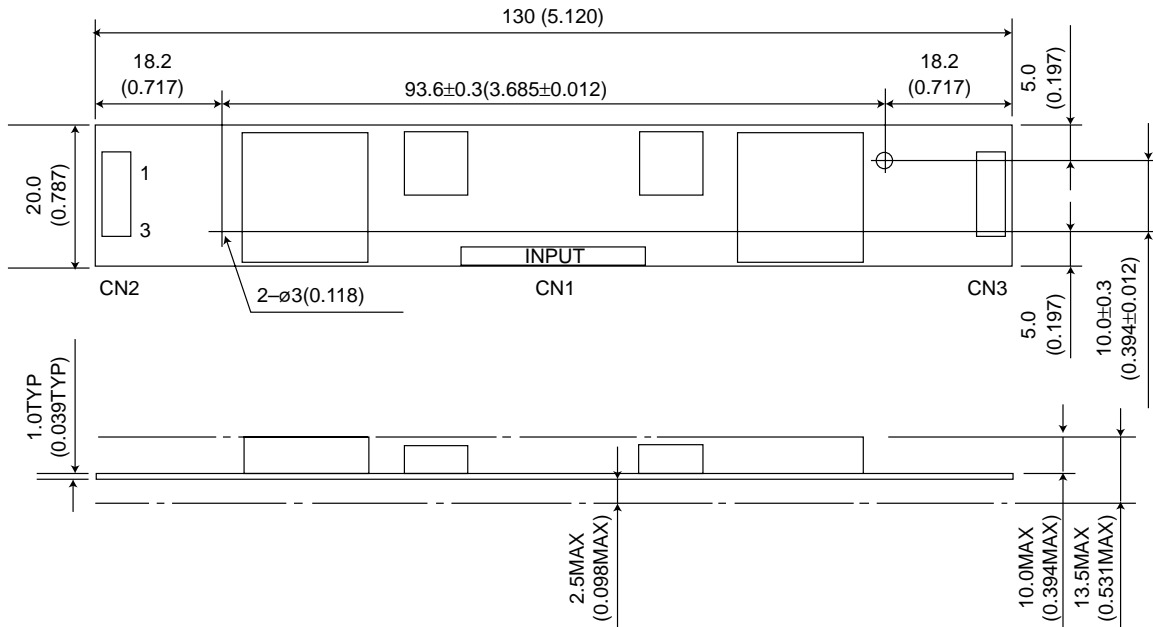

© Copyright 2001 Taiyo Yuden (U.S.A.), Inc. Specifications subject to change without notice.



TAIYO YUDEN

world leaders in materials and electronics technology

Taiyo Yuden (U.S.A.), Inc.
 1770 La Costa Meadows Drive, San Marcos, CA 92069
 (760) 510-3200 / Fax: (760) 471-4021
(800) 493-6835 www.t-yuden.com powerproducts@t-yuden.com



FM 32227

Model LS520A

Tech Notes

Connection Diagram

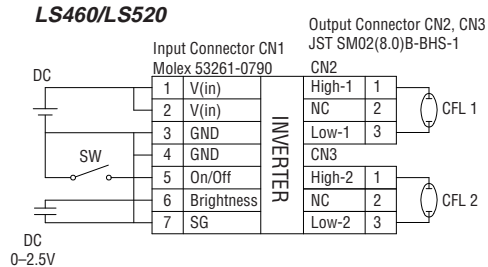

Output Current Optimization Method

Maximum output current can be adjusted by applying bias voltage between brightness control pins as shown below.

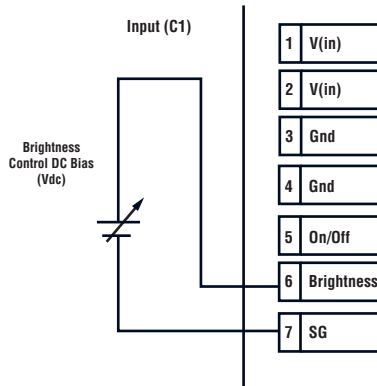

DC Bias	Typical Output Current	Maximum Output Current
0.00 V	6.8 mA	7.7 mA
0.75 V	6.5 mA	7.0 mA
1.00 V	6.0 mA	6.5 mA
1.25 V	5.5 mA	6.0 mA
1.50 V	5.0 mA	5.5 mA
1.75 V	4.5 mA	5.0 mA
2.00 V	4.0 mA	4.5 mA
2.25 V	3.5 mA	4.0 mA
2.50 V	3.0 mA	3.5 mA
3.00 V	2.5 mA	3.0 mA

On/Off Control

The on/off control is achieved by using the on/off pin on the input side of LS520. The circuit for the remote on/off circuitry consists of an active low TTL switch. When the circuit is open, the IC Vcc is cut off. When the circuit is closed, IC Vcc is activated. A mechanical switch or a TTL/CMOS gate needs to be placed between the remote on/off pin and ground creating a condition where the circuit is closed to activate the inverter. Either one of the following will be required for the inverter to operate:

One recommended use of logic switch for remote on/off is shown in the diagram below. Electrical specification for on/off terminal is Low 0 to 0.4V, -0.4 mA or higher when switch is closed.

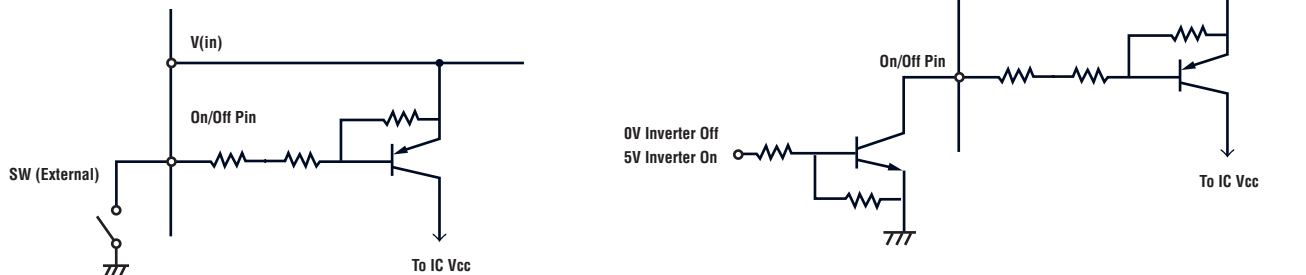

1. Tie on/off pin to ground.
2. Add mechanical switch between on/off pin and ground, close switch.
3. Add TTL/CMOS switch between on/off and ground. Circuit must be closed for unit to operate (as shown above right).

Model

LS520A

Tech Notes

Brightness Control Using a Potentiometer

The LS520 brightness control is done by applying a DC bias of 0 to 2.5V to the brightness control pins. Unlike the single tube inverters like the LS380s, brightness control for dual tube inverters cannot be accomplished with a potentiometer. The reason for this is that the LS520 has a voltage follower, or a sub-regulator built into the unit to synchronize both outputs. This voltage follower compensates for resistive load to the brightness control circuitry.

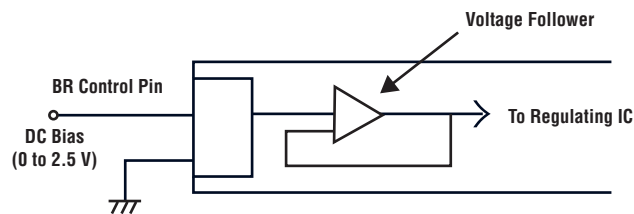

However, by using a voltage separator circuit consisting of a potentiometer, a virtual brightness control by potentiometer can be achieved.

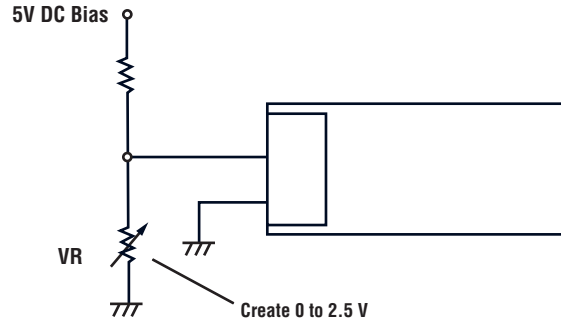

Note that current which will run between the brightness control pin will be in a trivial $3.0\mu\text{A}$ range.

Mean Time Between Failures (MTBF)

By using the MIL-HDBK 217E Condition Ground Benign method, the MTBF for the LS520 is calculated at 458,000 hours.

© Copyright 2001 Taiyo Yuden (U.S.A.), Inc. Specifications subject to change without notice.



TAIYO YUDEN

world leaders in materials and electronics technology

Taiyo Yuden (U.S.A.), Inc.

1770 La Costa Meadows Drive, San Marcos, CA 92069

(760) 510-3200 / Fax: (760) 471-4021

(800) 493-6835 www.t-yuden.com powerproducts@t-yuden.com



FM 32227